



Multi-Lader

ML 300



Multi-Lader ML 300

| | | | |
|---|---------|---|---------|
| A | 2651 mm | J | 160 mm |
| B | 124 mm | K | 380 mm |
| C | 35 mm | L | 66° |
| D | 1162 mm | M | 28° |
| E | 1708 mm | N | 900 mm |
| F | 1867 mm | O | 970 mm |
| G | 2052 mm | T | 1404 mm |
| H | 1364 mm | Q | 29° |

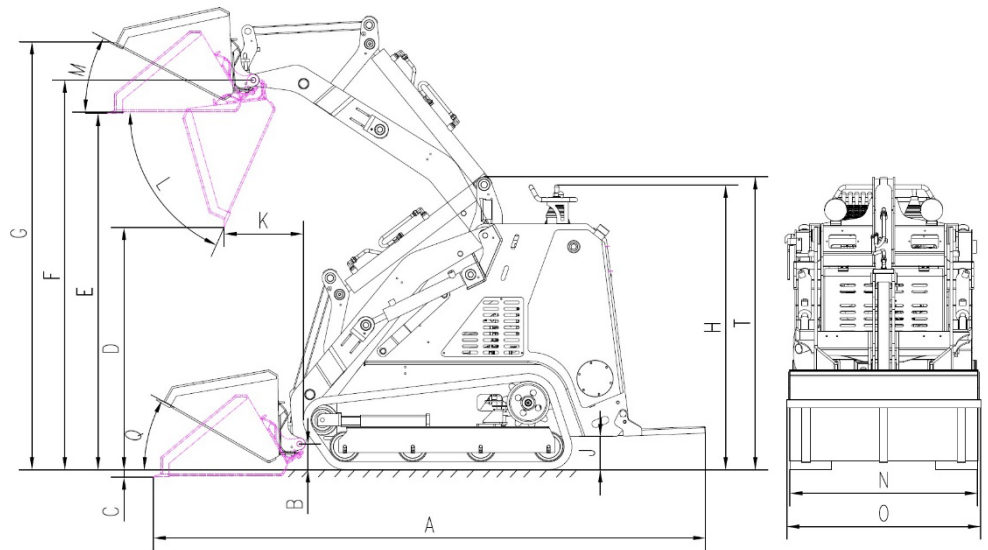

Technische Daten

| | |
|----------------------|---------------------|
| Motor | |
| Perkins Diesel Motor | 403 J-11 |
| Hubraum | 3 Zyl. / 4-Takt |
| Leistung | 688 cm ³ |
| Betriebsdrehzahl | 18,4 kW (25,0 PS) |
| | 66,8 Nm @ 2100/min |
| Starteinrichtung | Elektrostarter |

| | |
|--------------------------|--|
| Antrieb | hydrostatisch |
| Lenkung | durch Hydraulikmotor Danfoss |
| Multi-Ventilblock | Hydrocontrol Italy |
| Hydraulikpumpe | Permco USA |
| Besonderheit | mit Schnellwechseleinrichtung Joysticksteuerung, Elektrostart |

| | |
|-------------------------------------|----------------|
| Betriebsdaten | |
| Maschinengewicht ohne Anbaugerät | 1100 kg |
| Max. Nutzlast | 300 kg |
| Max. Betriebsgewicht (beladen) | 1350 kg |
| Kippeinrichtung | hydraulisch |
| Steigfähigkeit | max. 20° (36%) |
| Arbeitsgeschwindigkeit | 0 – 5 km/h |
| Öldruck | 180 bar |
| Fördermenge Ölpumpen | 24.6 ltr./min. |
| Schaufelinhalt Standardschaufel | 120 ltr. |

| | |
|----------------|--|
| Zubehör | 4 in 1 Schaufel, Anbaubagger, Palettengabel Greifzange (Kroko), Grabenfräse, Abbruchhammer, Erdborner Ø 200mm/300mm |
|----------------|--|



Baumaschinen GmbH

Niederhöchstädter Str. 71-73 D-61476 Kronberg
 Tel.: 0049-(0)6173-68558 Fax: 0049-(0)6173-68548
 E-Mail: info@powerpac.de Internet: www.powerpac.de